

MacGregor emergency box for steering gear

Guaranteed onboard access to critical spare parts
with increased safety and enhanced up-time



At your service



MACGREGOR

Designed to perform with the sea

These spare parts give you quick and easy access on board to critical spare parts. With an emergency box for steering gear you get guaranteed peace of mind and you can re-order your spares without any hassle.

Increase your ship's safety and reduce expensive down-time. Our emergency box contains the most critical electronic, hydraulic and mechanical spare parts. The spare parts within your personalised emergency box are carefully selected by our highly experienced MacGregor Global Lifecycle Support experts.

The spare parts are professionally packaged to prevent damage and supplied in a rugged padlockable box suitable for storage on board your vessel.

A user manual with hydraulic and electrical circuit diagrams is included to enable quick trouble shooting. In addition, a parts list with clear instructions how to re-order is provided.

Advantages

- Guaranteed onboard access to critical spare parts
- Reduction of expensive down-time
- Cost savings when compared to buying critical spare parts in an emergency situation
- Supplied ready for onboard storage
- Easy instructions for replenishing used parts
- Trouble-shooting information included

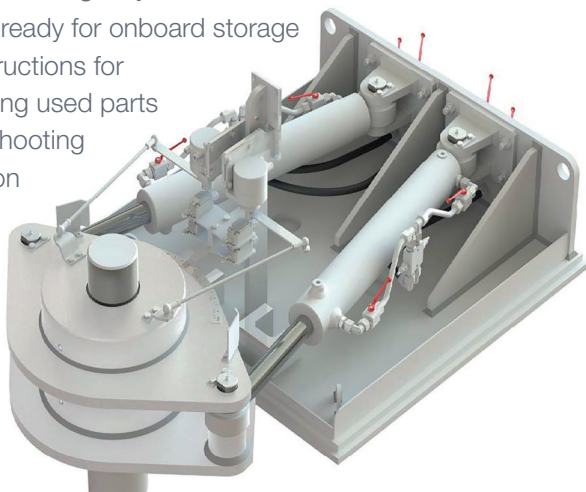

Included spare parts

As standard, we carefully select the critical spare parts for your particular steering gear. We are willing to adjust the scope of supply to include any additional items to match your specific needs.

The following spare parts are among those usually supplied as standard:

- Roof-shaped sealing set
- Pressure gauges
- Repair kit
- Solenoid pilot valve
- Couplings

The size of a standard box is 900 x 400 x 500mm.

Ordering

Please contact your MacGregor account manager or send an email to hatlapa.service@macgregor.com. When placing your order, please state the IMO number of the vessel and the serial number of the steering gear.

MacGregor shapes the offshore and marine industries by offering world-leading engineering solutions and services with a strong portfolio of MacGregor, Hatlapa, Porsgrunn, Pusnes and Triplex brands. Shipbuilders, owners and operators are able to optimise the lifetime profitability, safety, reliability and environmental sustainability of their operations by working in close cooperation with MacGregor.

MacGregor solutions and services for handling marine cargoes, vessel operations, offshore loads, crude/LNG transfer and offshore mooring are all *designed to perform with the sea*.

MacGregor is part of Cargotec. Cargotec's class B shares are quoted on NASDAQ OMX Helsinki Ltd.

Published by MacGregor. Copyright © MacGregor April 2017. All rights reserved. No part of this publication may be reproduced, stored, photocopied, recorded or transmitted without permission of the copyright owner.